



LTM-300 Series
Magnetostrictive Level Transmitter
Instruction & Operation Manual
Jan 2009

LTM-300 Magnetostrictive Level Transmitter Instruction and Maintenance Manual

Table of Contents

<u>Section 1. Transmitter Overview</u>	<u>Page</u>
1.0 General Description	1
1.1 Level Transmitter	1
1.2 Gage Mounted Transmitter	1
1.3 Standalone Transmitter	1
<u>Section 2. Instrument Description</u>	<u>Page</u>
2.0 Transmitter Detailed Description	2
2.1 Theory of Operation	2
2.1.1 Primary Level	2
2.1.2 Level/ Temperature Transmitter	3
2.1.3 Level/ Interface/ Temperature Transmitter	3
<u>Section 3. Installation and Wiring</u>	<u>Page</u>
3.0 Strap-On Transmitter Installation	3
3.1 Standalone Transmitter Installation	3
3.2 Recommended Wiring, Single Loop	4
<u>Section 4. Specifications</u>	<u>Page</u>
4.0 Transmitter Electrical Specifications	4
4.1 Transmitter Sensor Tube	4
<u>Section 5. Calibration</u>	<u>Page</u>
5.0 Single Loop Calibration	4
5.1 On-Board Menus	5
<u>Section 6. Troubleshooting and Maintenance</u>	<u>Page</u>
6.0 Self Diagnostics (Via HART)	5
6.1 Calibration Problems	6
6.2 Magnetic Interference	6
6.3 Troubleshooting Power Supply Problems	6
6.4 Start Up	6
<u>Section 7. Field Insulation of Gages with Transmitters</u>	<u>Page</u>
7.0 Field Insulation	7
7.1 Insulation Jacket Warning Label.	7
<u>Section 8. Warranty and HART Protocol Option</u>	<u>Page</u>
8.0 Standard ISE/MagTech Warranty.	7
8.1 HART protocol Option Information	8-18

SECTION 1. Transmitter Overview

1.0 General Description

The LTM-300 is an electronic field instrument, suitable for installation in hazardous and non-hazardous industrial areas. Testing and certification has been obtained from different agencies for installation in specific areas.

This instrument is a two wire, loop powered smart transmitter, designed to measure and transmit an analog 4-20 mA signal and two digital outputs (optional) proportional to liquid level in a tank. The optional temperature output is configured via the HART communicator. Interface is auto-detect. Note: Both floats have to be present for auto-detection. The complete assembly includes a dual compartment explosion proof enclosure, and attached sensor tube.

Optional Features of the LTM-300 include:

- Second digital output proportional to an interface level (requires a second float of different specific gravity)
- Digital temperature output gives the liquid temperature and is typically used for display and/or calculation of mass.
- A variety of lengths and wetted materials to accommodate many different applications.
- Mass or Volume Information

Product Serial Number

Magtech assigns a unique serial number for each unit. The first two digits indicate the month of production followed by two digits, indicating the year of production. For example, serial number 0606 / 1234 describes a unit manufactured in June of 2006 with a serial number 1234.

1.1 Level Transmitter

In its simplest configuration, a single-purpose float rides up and down the sensor tube, totally surrounding it. A multi-purpose float may also be used to activate the sensor, such a float being placed inside a liquid isolation pipe, (i.e. Mag-Gage) and strategically located within a certain longitudinal distance from the sensor tube. In either case, the float has a somewhat lighter specific gravity than the liquid whose level is to be measured, so that it is partially submerged at the interface of interest. As the tank level changes, the float tracks the change and continuously activates the sensor in the tube. The electronics in the housing process the changing signal and update an analog 4-20 mA output. This analog output is precisely proportional to the liquid level in the tank.

1.2 Gage Mounted Transmitter

The LTM-300 may be strapped to the side of the MagTech LG series magnetic level indicator. In such an installation, it is used as an accessory transmitter for the visual level gage. The same float used to activate the magnetic gage is also used to transmit a signal to the magnetostrictive sensor of the LTM-300.

In the above right shown installations, the transmitters may be calibrated for the same range as the visual indicator on the Mag-Gage, or for part of the range (See Section 3).

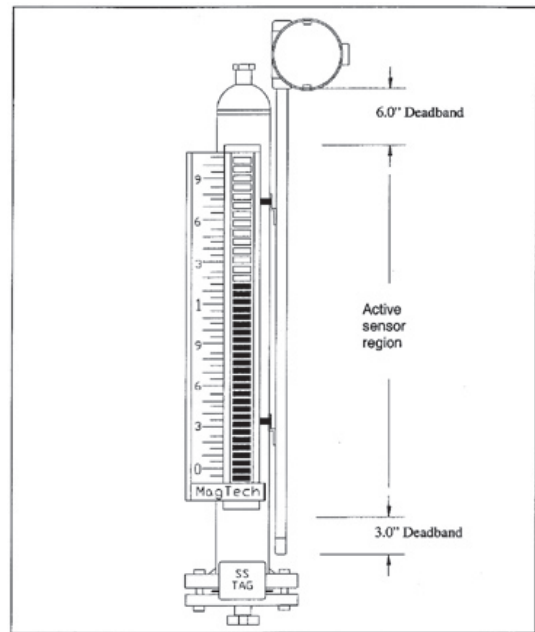

LTM-300 Mounting Configuration
Style B & C LG Series Gage

1.3 Standalone Transmitter

When a companion magnetic gage is not present, the LTM-300 is inserted into the tank with its own float around the sensor tube. A stilling well may be optionally used inside the tank or, in case of high temperatures; an external chamber may be the housing of the tube and float assembly.

Note 1:

When a stilling well is used, care should be exercised when installing the tube to center it in the chamber so that the float can freely travel the entire length of the probe. Stilling wells are required for transmitters over 10 feet.

Up to two floats may be used with the LTM-300. The second float will typically sense the interface level of the heavier of the two fluids in the tank. The specific gravity of the second float will be such that it can be totally immersed in the lighter fluid.

Note 2:

When two floats are used, a minimum separation of about three inches is recommended to prevent interference between floats.

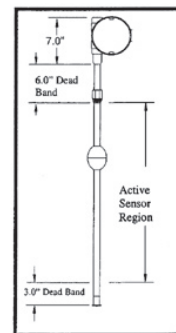

Single Float Transmitter

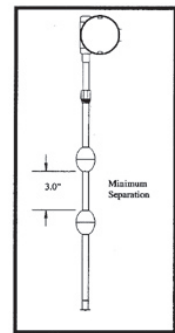

Dual Float Transmitter

The calibration range of the transmitter may be field stored in non-volatile memory by using the float and push buttons. The push buttons are located on the front panel inside the conduit. See section on Calibration for more details.

SECTION 2. Instrument Description

2.0 Transmitter Detailed Description

The LTM-300 is an assembly of two major components:

- The Sensor Tube Assembly. This is a 5/8" diameter stainless steel probe, sealed on one end, with the magnetostrictive waveguide in its center. In addition to the magnetostrictive waveguide, the tube also houses the optional temperature sensor and the detector electronics. The tube is made to lengths of 2-30 ft. in rigid construction.
- The Electronics Housing. The extruded aluminum housing has two separate compartments. One side contains the microprocessor board assembly and calibration push buttons. The other side contains the wiring termination board. The electronics module is connected to the detector board of the sensor tube assembly via a plug-in cable.

The main board is surface mounted component construction utilizing the latest in integrated circuit technology. It contains a high-speed micro controller with a HART modem, D/A Converters, A/D Converter (for optional temperature) and all other accessory components.

2.1 Theory of Operation

The LTM-300 Level Transmitter is based on the principle of magnetostriction first used for digital delay lines and later for precision distance or displacement in the machine tool industry. The principle, if designed and applied properly, has potentially very high measurement resolution, typically better than 0.001 inch. In the machine tool industry such a high resolution is desirable. In the liquid level measurement application, however, a resolution of 0.01 inch is more than adequate.

In a brief description, the magnetostrictive principle consists of a wire extruded and heat treated under carefully chosen conditions to retain desired magnetic properties, which is pulsed by a circuit with a relatively high current pulse. The high current pulse produces a circular magnetic field as it travels down the wire at the speed of light. Another magnetic field generated by a permanent magnet, placed near or around the wire at some distance from the point of entry of this pulse, interferes with the magnetic field of the pulse and torsional force results at the collision point.

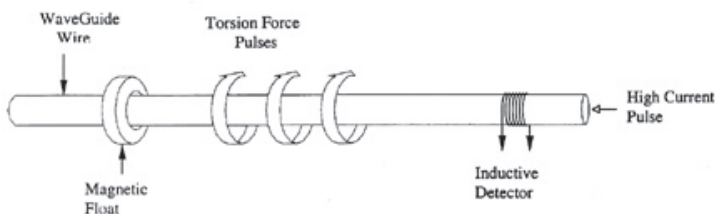

The effect of this torsion force is to twist the wire at this point producing a torsion wave traveling towards both ends of the wire. The propagation time of this wave is measured precisely and, if the wire properties remain stable, it is very repeatable at about 5-10 microseconds per inch, which is approximately the speed of sound in that medium. By measuring the exact number of microseconds it took the torsion wave to reach a designated termination point of the wire, the distance to the magnet from this termination point can be easily calculated.

A high-speed micro controller is utilized in the design to process and calculate the elapsed time measurement. Accurate crystals are used for the time base to resolve sub-microsecond timing increments. The binary number, equivalent to the microseconds of the echo travel time, is written to an output D/A Converter and subsequently converted to a 4-20 mA signal proportional to the item measured. The larger the number of microseconds there are, the greater the distance of the float from the head of the transmitter.

Calibration routines are included in the software to scale the 4 and 20 mA points for any distance desired. Even reverse calibration is a simple task using the software routines. Reverse calibration is desirable if ullage instead of full level is required, or when the probe is installed with bottom mount head. See Section on Calibration for further details.

The LTM-300 transmitter can have as many as three outputs. The first is a 4-20 mA output, the second and third are digital outputs. The LTM-300 is available with the following output configurations:

All LTM-300 Units have HART as a standard.

1. Primary Level. Single output version with only one variable that will output a 4-20mA signal for level.
 2. The second and third outputs are digital and can be configured to measure temperature and/or interface level. The digital outputs are read via HART.
1. Primary Level Transmitter. The most basic version of this transmitter, is that it computes the distance between the float and the detector from the elapsed time measurement. A specific time window becomes active only for a short time after the interrogation pulse is applied to the waveguide. Any feedback signal, received before and after this window, is rejected as noise. Even signals received during the active window are evaluated and filtered so that only high integrity data is accepted.

The conditioned signal is converted to a percent of full-scale number and written to the D/A Converter. The scale is defined by the calibration procedure and it corresponds to the output span (4-20mA) of 16.00 mA.

A deadband, corresponding to approximately six inches next to the detector, is fixed in the software and the float is not permitted to enter this area. If this happens, readings may be erratic or the output may go to FAIL.

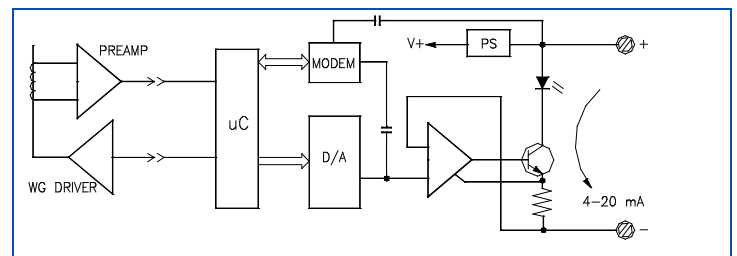

Basic Level Transmitter Simplified Block Diagram

Facilities are provided to field calibrate the range of the 4-20 mA output using the actual position of the float and pressing a push-button on the front panel to set the 4-20 mA point.

Provision, accessed through HART or front panel, is made for a FAIL mode to High (20.8 mA), Low (3.75 mA) or "Hold last Value."

A HART modem enables the transmitter to communicate serially over the 4-20 mA DC signal with a host computer or a handheld terminal.

2. Level/Temperature. An optional temperature sensor is embedded inside the bottom tip of the probe, and it can be calibrated to give the temperature of the liquid in the tank on the second or third

The sensor is a 1000 ohm platinum RTD type and its resistance is converted to a binary signal by a high resolution A/D Converter. The temperature range is set to order and stored in non-volatile memory before shipment.

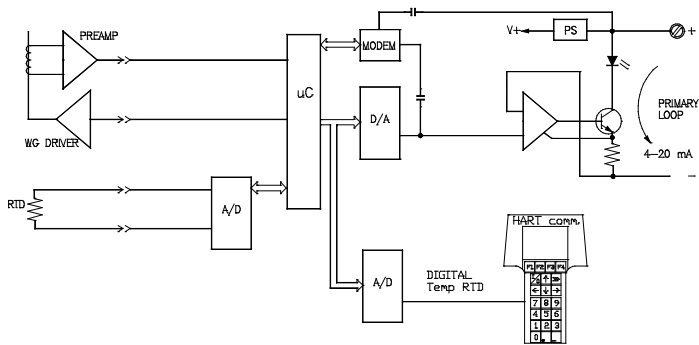

- Level/Interface. A second float may be added below the first one, and the second output will be calibrated automatically. The second time interval is measured in the same manner as the first and added to the first to derive the position of the heavier float.

The same six inch dead zone applies to the measurement of the second level although the reasons are different. This will typically correspond to a physical separation of the two floats by approximately three inches. The float size, geometry, magnetic strength all play a factor in how close the two floats can get without interfering with each other.

SECTION 3. Installation and Wiring

3.0 Strap-On Transmitter Installation

CAUTION:

During installation, do not attempt to twist or turn the head of the transmitter. Damage to the detector assembly may occur if the head is rotated. If the head is loose, please notify the factory.

The LTM-300 can be mounted to the side of a MagTech LG series level gage using a special mounting bracket and stainless steel hose clamps. When mounting the transmitter to an LG series gage the active sensor region of the probe should fall within the centerline of the process connections on the gage. If the transmitter deadband region is inside the centerline of the process connections the transmitter will not output an accurate measurement because the active region of the probe is too short. When placing an order for a transmitter to accompany an existing gage it is important to indicate the style of the gage, the temperature and the center-to-center dimensions. Calibration of the probe will be factory set along the active region of the probe; however, a field calibration may have to be performed to match the probe to the desired control room specifications.

If a transmitter is being purchased for an interface gage, the calibration for the probe should be done in the field to ensure a proper control room

reading. For long transmitters it may be desirable for the operator to have the electronics housing mounted at the bottom of the gage for easy access. THIS MUST BE SPECIFIED AT TIME OF PURCHASE.

Installation Note (European):

The cable entry devices and blanking elements of unused apertures shall be of a certified flameproof type, suitable for the conditions of use and correctly installed.

3.1 Standalone Transmitter Installation

The LTM-300 stand-alone transmitter comes equipped with a 3/4" compression fitting, mounted approximately 6.00" below the electronics housing. The fitting is placed in this area to ensure the transmitter is calibrated in the sensor tubes active region. Refer to the stand-alone drawings for a visual description of the transmitter features. Optional mounting configurations are available upon request.

The magnetic float used in the stand-alone unit is designed to travel up the sensor tube with the change in fluid level. If build-up of process or contaminates should restrict the movement of the float, the transmitter sensor tube will have to be cleaned or the float may have to be replaced with one that has a wider inside diameter. The floats are designed to match the pressure and specific gravity for the process being measured and come in various materials ranging from stainless steel to kynar.

The magnetic float can be changed out at any time to accommodate the processes being measured. The float stop, located at the bottom of the transmitter, can be removed to allow the float to slide off the sensor tube.

PLEASE NOTE:

If using a transmitter configured for dual level output or interface measurements, remember to slide the float with the lightest gravity range first.

INTERCONNECT WIRING (CSA & FM)

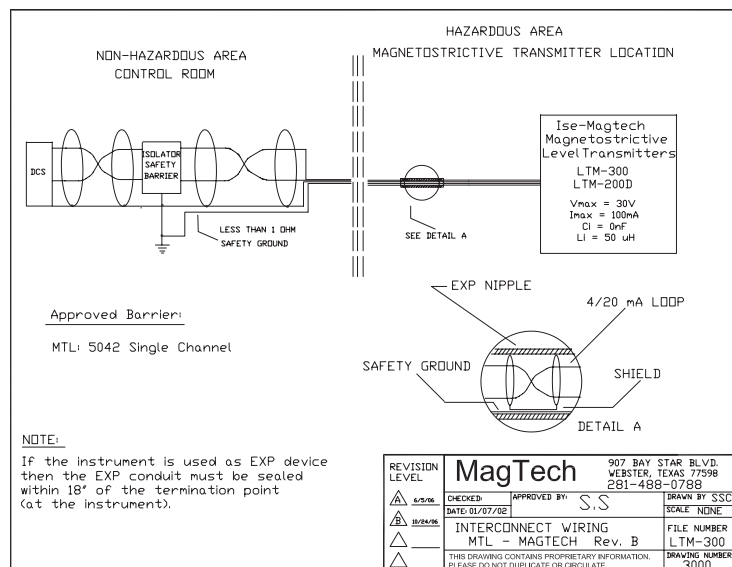

3.2 Recommended Wiring, Single Loop

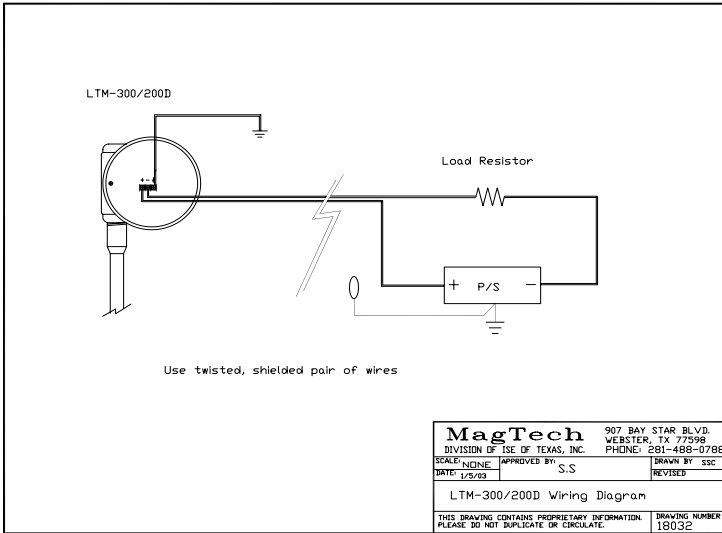

SECTION 4. Specifications

4.0 Transmitter Electrical Specifications

Supply Voltage:	15 to 36 VDC
Repeatability:	.005% of full scale or .010%, whichever is greater
Non-Linearity:	.01% of full scale or .030%, whichever is greater
Level Sensor Accuracy:	.01% of full scale or .020%, whichever is greater
Analog Output Resolution:	.025% of full scale, (1) 4/20 mA primary level.
Output:	One 4-20 mA output: Level Option: Two Digital Outputs: Temperature and/or Interface via HART only.
Calibration:	Zero and span field adjustable with push buttons or HART. Secondary level is auto-connect. Temperature is configured via HART or AMS only.
Diagnostics:	On board diagnostics for troubleshooting via HART or AMS
Dampening:	1 to 25 seconds (field adjustable) via HART
Oper. Temp. (electronics)	-58 to 185°F (-50 to 85°C)
Housing:	Explosion Proof, Dual Compartment, H" NPT, Epoxy Coated Aluminum
Polarity Protection:	Diode in series with the loop
Hazardous Location Approvals:	FM - Exp Cl I, Div. I Grp. B C D, Cl II Grp. E F G, Cl III
CSA - Ex ia (Intrinsically Safe):	Cl I, Div. I, Grp. C D
Exp (Expl. Proof):	Cl I, Div. I, Grp. B C D, Cl II, Grp. E F G, Cl III
IECEX (Expl. Proof):	Ex d IIC T4
Atex (Expl. Proof):	EEx d IIC T4 Ex II 2 G

Ambient Temp. Range	-20°C ... +40°C (-4°F ... 104°F)
Humidity Limits:	SAMA PMC 31.1-5.2
Vibration Limits:	SAMA PMC 31.1-5.3
RFI Limits:	SAMA PMC 31.1-20 to 1000 MHz up to 30V/m

4.1 Transmitter Sensor Tube

Material:	316ss standard, optional Hastalloy, Monel, Kynar coated
Operating Temperature:	-50 to 302°F (-50 to 150°C)
Maximum Pressure:	2000 psig @ 300°F
Range:	12" to 30 ft.

SECTION 5.0 Calibration

5.0 LTM-300 Output Configurations

The LTM-300 transmitter is available in three different configurations. A single output version with only one variable that will output a 4-20 mA signal for level. The second configuration is a transmitter fitted with a second float to provide a digital output for interface level in addition to the primary level output. The third configuration is one 4-20 mA signal for Primary level and two additional digital signals with one for interface level and one for temperature output.

Configurations two and three have independent calibration as well as independent outputs. These configurations have the capability for calibration and measurement using a HART protocol communications system. The HART specifications and conditions will be discussed in detail under the HART COMMUNICATION section of the manual. The temperature range is factory set from -50°F to 300°F.

Pushbutton Calibration

- Step 1 - Move jumper to the write enable position (see below)
 - Step 2 - Move your float or magnet to the 4mA (0%) point on the probe
 - Step 3 - Press the ENTER button on the display until "Trm Snsr" is displayed. Press the UP arrow to display "Yes" and press ENTER.
 - Step 4 - The display will read "Trim Zero". Press ENTER.
 - Step 5 - Move the float or magnet to the 20mA (100%) point on the probe.
 - Step 6 - The display will read "Trim Span" with a value above. Using the arrow buttons, input the correct distance from the zero point and press Enter. Calibration is now completed.
- Note: "Sel Lngth" value is factory set and should not be changed. Doing so will cause a level error indication.

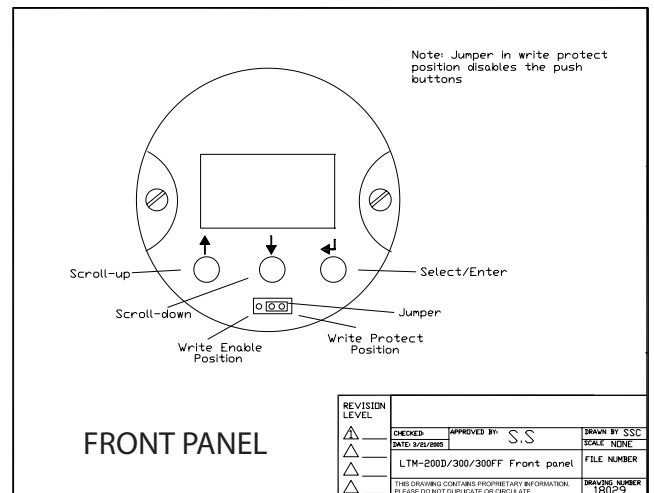

Displays	1 2 3. 4 5 in Level
Level Measurement Display - in inches	4 5 6 7. 8 cm
Level measurement Display - in centimeters	9 0 1 2 3. mm Level
Level Measurement Display - in millimeters	5 6. 7 8 9 ft Level
Level Measurement Display - in feet	2 3. 4 5 6 m Level
Level Measurement Display - in meters	1 2 3. 4 5 in In -
Interface Measurements - same decimal positions as Level Only if configuration set to Level+Interface or All	3 2 F Temper
Temperature Measurements - same decimal positions for F or C Only if configuration set to Level+ Temper or All	1 2. 3 4 mA Output
Output Current	5 6. 7 8 % % Range
Percent of Range	
Configuration Screens (Up / Down arrows choose options) Press Select to Enter.	
Model Number - Model 300	L T M 3 0 0
Select sensor length - Input overall sensor length (Length = end to weld)	XXX.X In Sel Lngth
Level Units - rotates starting at present units (> ft<>m<>in<>cm<>mm>)	Sel Unit in
PV - only if Interface available - rotates starting at present PV (>Level<>Interf>)	Sel Level PV
Alarm - rotates starting at present alarm (>High<>Low<>Hold Out>)	Hold Out Sel Alarm
Range Change Choose Yes to Select Range - Display starts with NO	No Chg Rng e? 1 2. 3 4 in Sel LRV
Lower Range Value	4 5. 6 7 in Sel URV
Upper Range Value	3. s Sel Damp
Damping - From 1 to 25 - Will not allow 0 or negative numbers.	No Trn Sns r ?
Sensor Calibration Choose Yes to perform Sensor Trim (Display starts with No)	Trim Zero
Zero Trim - Set float to the 4 mA mark (0%) and then Select. Data not required.	1 2 3. 4 5 in Trim Span
Span Trim - Move the float to the 20mA mark (100%) on the probe. Using the arrow buttons input the correct distance from the zero point and then Select.	.00 in Set Off
Level Offset-Enter the desired value of the offset from the current zero and Press Enter. This will show a level offset at 4mA. i.e. 4mA will be reported @ 5.0" if 5.0" was selected.	No Trim D ac ?
Dac Trim Choose Yes to perform Dac Trim - Display starts with No	Trim 4 mA
Dac Trim - 4mA Point - Press raise or lower depending on value of loop current.	Trim 20 mA
Dac Trim - 20mA Point - Press raise or lower depending on value of loop current.	8. 0 0 mA Loop Test
Loop Test - Input Value This will continuously vary the loop current as the user presses the Raise or Lower buttons. Exits when user depresses Select button.	
Exit to Displays	

SECTION 6. Troubleshooting and Maintenance

6.0 Diagnostics are Via HART

6.1 Calibration Problems

If the transmitter does not appear to calibrate properly, or has an erratic output, check the deadband of the sensor tube and ensure that the float is within the active region of the probe. The active region of the sensor tube is typically marked with 20mA and 4mA stickers when the unit is calibrated before shipment.

If the output is still erratic, try disconnecting the power momentarily by unplugging and re-plugging-in the terminals. If a glitch was stored in RAM memory, this will generally clear it.

6.2 Magnetic Interface

It is possible for the LTM-300 to be magnetically biased or have residual magnetic energy stored along the length of the waveguide. These magnetic anomalies can interfere with the signal-to-noise ratio and the stability of the output signal itself.

If this appears to be the case, a gage float magnet (or any magnet available) may be run along the length of the sensor tube, past the head of the transmitter, in an even motion and without stopping. This will usually clear all such magnetic anomalies.

CAUTION:

Never move a magnet in a perpendicular motion from along the sensor tube. This will always leave a residual field in the waveguide which will cause the transmitter to give an erratic output

6.3 Troubleshooting Power Supply Problems

The LTM-300 is designed to operate with a supply voltage of 15-36 vdc (at 20 mA) across its terminals without affecting the mA signal. The most common loop supply used is 24vdc.

It is found sometimes that additional resistance in the loop is necessary, either in the form of a second load resistor or higher resistance safety barrier. This will appear to limit the maximum output of the transmitter to below 20 mA. The transmitter will generally perform correctly up to this point. To resolve this problem, the voltage of the loop supply must be increased somewhat. Even a slight increase by one volt may be sufficient and many supplies have such an adjustment.

All connections must be checked for improper wiring or polarity before power is applied. The LTM-300 has series diodes preventing the reverse polarity from entering and damaging the circuitry. If power is applied and the signal is 0.0 mA, chances are good that the polarity is reversed.

TERMINAL BOARD

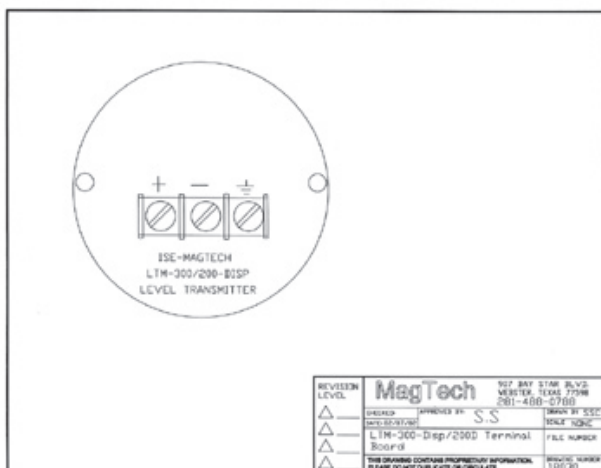

6.4 Start-Up for Gage-Mounted LTM Transmitters

Gage and Transmitter Installation

1. Visually inspect Mag-Gage and transmitter installation to insure transmitter is positioned with the 4 mA and 20 mA labels directly adjacent to the process connections. Make sure transmitter is securely clamped and parallel to gage chamber.
2. Remove bottom flange and install float. Each float is clearly tagged with serial number of the Mag-Gage and process parameters. Top of float is clearly marked "TOP" to insure float is in right side up.
3. Inspect bottom flange for proper gasket and spring. This spring protects float and keeps it from dropping below the bottom process connection. To determine proper spring length measure "A" dimension of gage. This is the length from the center of the bottom process connection to face of the bottom drain flange. Length of spring should be

("A" DIMENSION) (-) Minus (Float Length + 2 inches)

EXAMPLE: "A" Dimension is 14", Float length is 12", + 2" = 4" Spring Length.

$$14 - 12 + 2 = 4" \text{ spring}$$
4. Float is properly installed if the bottom 2-3 flippers on gage indicator have flipped.

NOTE: There is a top spring in the Mag-Gage to protect float and prevent it from passing the top process connection. DO NOT REMOVE EITHER SPRING.

Transmitter Check-out and Calibration

NOTE: The LTM Series Transmitters are 24VDC Loop powered (2-wire) and require a minimum of 15 Volts at 20 mA.

1. Using a HART compatible loop calibrator, connect the "+" terminal on the LTM to positive lead of calibrator and the "-" terminal on the LTM to negative lead of calibrator.
2. With float in the gage at 4mA, the output of the LTM should be 4mA. Connect the HART Communicator to the transmitter. Upon power up, the HART Communicator should read the LRV (lower range value) or 0 inches at 4mA.
3. With float in the gage at 20mA, the output of the LTM should be 20mA. HART should also display URV (upper range value) or span length in inches at 20mA.
4. To insure complete functionality of gage and transmitter, fill the gage chamber with liquid and drain slowly to observe transmitter and gage are tracking properly.

5. If no float is present, or magnetic field is lost, HART Communicator will display "LEVEL SIGNAL LOST"
6. For calibration using HART, or to change range consult HART section of this manual.

Note: In service over 400 Deg F (204C) Gages and Transmitters should be properly insulated with transmitter OUTSIDE the blanket.

Note: During the installation or calibration of the LTM-300 level transmitter, the technician should be very careful not to move the magnet perpendicular to the sensor tube as this could leave magnetic indentation in the sensor wire. The LTM-300 level transmitter has an inductor located inside the bulkhead of the sensor tube. During operation of the transmitter, this inductor emits a magnetic field as current passes through the sensor wire. If an external magnet or the float comes in contact with the bulkhead, this can cause temporary magnetization of the coil, which means the coil is biased. In other words, the phase is reversed. If this occurs, the inductor should quickly recover. It may be manually reversed or de-magnetized very simply by "swiping" a magnet parallel to the bulkhead in an arching motion.

SECTION 7. Field Insulation of Gages with Transmitters

7.0 Field Insulation

We strongly recommend that experienced MagTech personnel do any insulation of the magnetic level gages with externally mounted transmitters.

If Cryogenic "Hard Skin" cold service type insulation is required, it MUST be done at the factory due to the custom "TUBE in TUBE: design necessary for removal of the transmitter if needed.

If insulation is going to be done in the field, then the following guidelines MUST be followed:

1. Flexible type insulation jackets (NOT HARD SKIN) are required and must be installed around the Mag-Gage chamber only. DO NOT cover the LTM 300 transmitter tube, as this may burn up the sensor and possibly the electronics.
2. After the insulation jacket is installed, the LTM 300 sensor tube must be re-mounted at its factory-preset distance from the Mag-Gage chamber and must be parallel to the chamber as well. (Small cut-outs in the jacket are required to re-attach the transmitter properly).
3. Make sure the 4mA markings on the sensor tube are re-aligned at the centers of the process connections.

7.1 Insulation Warning Label Supplied

-----WARNING-----
(When Insulating Gages)

MagTech Level Transmitters have a maximum operating temperature of 300°F. When insulating a Mag Gage and transmitter assembly in HOT service, keep the transmitter OUTSIDE the insulating material. Special blankets for this type of insulation are available from MagTech. For further information consult the factory. 1-800-221-3653

SECTION 8. Warranty and HART Protocol

8.0 Warranty

All MagTech products are warranted against defects in materials and workmanship of one year from date of shipment. The level gage chamber and process connections are guaranteed for the life of the tank or vessel to which it is attached. Floats are guaranteed for two years. MagTech will repair or replace at its discretion those products that fail to perform as specified, with the following exceptions:

1. Products repaired or modified by persons that are not authorized by MagTech.
2. Products subjected to misuse, negligence or accidents.
3. Products that are connected, installed, or otherwise used in such a way not in strict accordance with manufacturer's instructions.

This warranty is in lieu of any other warranty expressed or implied by any party other than MagTech. Repairs and/or replacements shall be at the sole discretion of MagTech based on the terms and conditions of this warranty. Defective products shall be returned to the factory prepaid by the buyer after obtaining a Return Authorization Number from MagTech. All warranty repairs or replacements will be performed at the factory in Houston. Surface return freight will be paid by MagTech. Factory warranties do not include field service. Field service warranty repairs will be at the buyer's expense. Consult MagTech for field service rates.

Any modifications to terms and conditions of this warranty will not be binding unless made in writing and signed by an authorized agent or official of MagTech.

NOTE: ALL MAGTECH GAGES SHOULD BE UNPACKED AND THOROUGHLY INSPECTED UPON RECEIPT. GAGES ARE SHIPPED FOB FACTORY AND ARE FULLY PROTECTED AGAINST DAMAGE OR LOSS DURING SHIPMENT. ANY CLAIMS FOR PARTS DAMAGED DURING SHIPMENT SHOULD BE SUBMITTED WITHIN 15 DAYS OF RECEIPT OF GOODS BY CUSTOMER.

8.1 HART Protocol Option Information

HART Communicator Overview

This section presents the major screen selections available to the user. The HART Communicator screens are shown on the left and a description of the screen and user information is given on the right.



When the HART Communicator is connected to the transmitter and turned on, the first screen that is seen by the user is the root menu screen. If the transmitter is configured as Level Only or Level plus Temperature, the screen to the left shows the information displayed to the user.



However if the transmitter is configured as Level plus Interface or Level plus Interface plus Temperature and Interface has been selected as the Primary Variable (Interface controls the current output), the screen to the left shows the information displayed to the user.



When the user selects the top menu entry on the root menu, Device setup, by using the right arrow, the next screen displays five menu selections available to the user. Each of these menu selections will provide detailed information about a specific portion of the transmitter as detailed in the following sections.



If the user selects the Process variables menu from the Device setup screen, the next screen displays the current values for all of the dynamic variables. If the transmitter is not configured for Interface, the entry "Interf" is not displayed. If the transmitter is not configured for temperature, the entry "Temper" is not displayed.

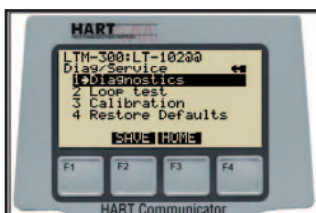

If the user selects Diag/Service menu from the Device setup screen, the next screen displays further menu selections to the user. These selections will be presented in more detail in the section titled Diagnostics and Service following this Overview.



If the user selects Basic setup from the Device setup screen, the next screen has a mixture of further menu selections and detailed information. This screen displays the name of the variable that is controlling the output current (PV), the tag and the Alarm type. In addition this screen presents the procedure to select the Primary variable (PV) if the transmitter is configured with both Level and Interface. It also displays the menu that will allow the user to change the range values. The procedure used to select the PV and perform the re-ranging of the transmitter will be presented in more detail in the section titled Basic Setup.



If the user selects Detailed setup from the Device setup screen, the next screen displays further menu selections to the user. These selections will be presented in more detail in the section titled Detailed Setup



Finally, if the user selects Review from the Device setup screen, a series of screens can be accessed that displays the value of each of the parameters of the transmitter. The user may select PREV or NEXT to continue with the list or EXIT to return to the Device setup screen. As the user scrolls through the list the only way to end this series of screens is to select EXIT since the list is a continuous loop through the parameters.

Diagnostics and Service



The user accesses this screen by selecting Diag/Service from the Device setup screen. There are to further menu selections, Diagnostics and Calibration, and two procedures, Loop test and Restore Defaults that the user may select from this screen.



If the user selects Diagnostics from the Diag/Service screen, he is given the choice of viewing the complete diagnostics status by selecting Operation Status or Cal Status, only viewing the off-normal status by selecting View status and if a maintenance status bit is set, to reset that bit as shown below.



If the user selects Operation Status from the Diagnostics screen, he is able to view all of the status bits indicating the health of the transmitter operation. If the entry is labeled OFF, that means that the entry is in normal operating conditions. If the entry is labeled ON, that means that the transmitter diagnostics has detected an abnormal condition and the user needs to take corrective action.



Then the HART Communicator will report the results to the user in sequence. In the example given here, the diagnostics has detected a problem with the Level measurement that may require user intervention. The user must acknowledge this problem by pressing OK to continue with the status.



The user is able to scroll down through the list to check each status bit. In the example given, the transmitter diagnostics has detected a problem with the Level measurement that may require user intervention. If the transmitter is not configured for Interface or Temperature, those status bits will always be listed as OFF. To return to the Diagnostics screen, the user must press EXIT.



Also in the example given, the diagnostics has detected that the Level Gain constant is out of range. The user should then correct this problem by trimming the Level Sensor as discussed below in the Calibration selection. The user must acknowledge this problem by pressing OK to continue with the status.



If the user selects Cal Status from the Diagnostics screen, he is able to view all of the status bits related to the calibration of the transmitter. User calibration is required for Level, Temperature and DAC output. If the transmitter diagnostics detects a calibration constant out of range, this will be reported by one of the status bits being set ON.



When the HART Communicator has completed the list of ON status bits, it reports the completion of the transmitter status. The user must acknowledge the end of the list by pressing OK to return to the Diagnostics screen.



The user is able to scroll down through the list to check each status bit. In the example given, the diagnostics has detected that the Level Gain constant is out of range. The user should then correct this problem by trimming the Level Sensor as discussed below for the Calibration selection. To return to the Diagnostics screen, the user must press EXIT.



Two of the Operation status bits (Level Maintenance Needed and Interface Maintenance Needed) when set by the transmitter diagnostics will remain set including power cycles until reset by the user. After the user has corrected the maintenance problems, these status bits should be reset by accessing the Reset Maintenance procedure.



If the user selects View status from the Diagnostics screen, the HART Communicator will send a command to the transmitter to report all of the conditions that are not normal. Any status items not reported are within the normal range of operation or calibration.

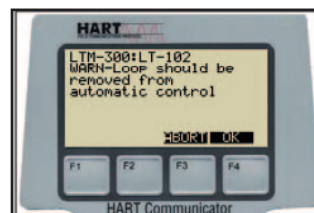

When the user selects the Reset Maintenance option, the HART Communicator displays the warning message that the loop should be removed from automatic control during this procedure.



The HART Communicator issues a command to receive the results of the transmitter diagnostics. During this process, the HART Communicator will ask the user to wait until the results are available.



The HART Communicator then asks the user to select YES or NO for the procedure to continue. As shown here, the user selects YES to continue. Then the HART Communicator sends the command to reset the maintenance needed status bits.



The HART Communicator informs the user that the maintenance flags have been reset when the transmitter has replied to the reset command. The user must acknowledge this information by pressing OK to continue.



If the user wishes to specify a loop current other than 4mA or 20mA, he must select the option Other and then press the ENTER key.



The user is then notified that the loop may now be returned to automatic control. After the user presses OK the HART Communicator returns to the Diagnostics screen.



The user must then input the exact value of loop current desired. After entering the value, he must press ENTER before the procedure continues. For example, the value 12.00 is input on the screen to the left.



The user must use the left arrow to return to the Diag/Service screen.



The HART Communicator will then command the transmitter to set the loop current to 12.00mA and then it will dynamically read the value of loop current that the transmitter has applied. To return to the previous screen, the user must press OK.



If the user selects Loop test from the Diag/Service screen, a procedure will begin that will allow the user to set the loop current to a value desired to perform a loop test function.



To exit the Loop test procedure, the user must select the option End and then press the ENTER key.

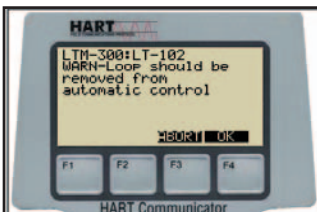

When the user selects the Loop test option, the HART Communicator displays the warning message that the loop should be removed from automatic control during this procedure.

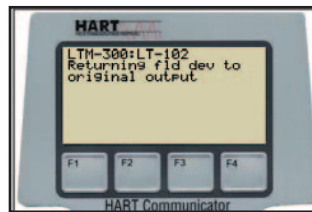

The HART Communicator then issues the command to the transmitter to return to the measurement mode as it was before entering Loop test.



The user is presented with four selections as shown on the screen. The 4mA and 20mA selections will set those values while selecting Other will require the user to input the exact loop current that is desired. The procedure will be exited if the user selects End. The example shows the user selection 4mA. The user must press ENTER before the procedure continues.



The user is then notified that the loop may now be returned to automatic control. After the user presses OK the HART Communicator returns to the Diag/Service screen.



The HART Communicator will then command the transmitter to set the loop current to 4mA and then it will dynamically read the value of loop current that the transmitter has applied. To return to the previous screen, the user must press OK. The procedure is exactly the same for the 20mA selection option



If the user selects Calibration from the Diag/Service screen, a number of menu selections are available. The user must now select the type of calibration he desires to perform. The Scaled D/A trim will adjust the transmitter so that its current output at the 4.00mA and 20.00mA output values will agree with the plant standard current meter.



If it is desired to trim the digital level value, he may select a single point zero trim or a full level trim that requires the input of both the zero level value and some other level value preferably near the end of the level measurement tube.

If the transmitter is configured with temperature measurement, he may select a single temperature trim point at 0 deg C or a full temperature trim that requires trimming both at 0 deg C and some other temperature point near the upper end of the operating temperature range.



The transmitter, based on the data from the reference meter, will calculate a new value for the DAC zero calibration constant and change the output current based on the new constant. If the current read by the reference meter is now 4.000mA, the user must press ENTER. If not exact, the user must select No and press ENTER to try again.



The HART Communicator will now command the transmitter to set the current output to 20.000mA. The user must press OK when ready to have the current output set to 20.000mA.



When the device has set the current output to 20.000mA, the user is to enter the reference meter reading. For example, if the meter actually reads 19.975mA, that value is input with the keypad. The user must press ENTER when ready to proceed



The transmitter, based on the data from the reference meter, will calculate a new value for the DAC gain calibration constant and change the output current based on the new constant. If the current read by the reference meter is now 20.000mA, the user must press ENTER. If not exact, the user must select No and press ENTER to try again.

Output Current (DAC) Calibration

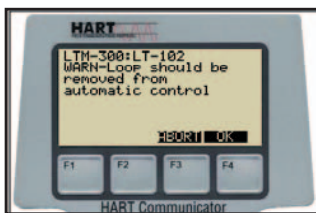

If the user selects Scaled D/A trim from the Calibration screen, this screen will appear reminding the user that the loop should be removed from automatic control before proceeding. When this has been done, the user must press OK to continue.



The next screen informs the user that the rest of the procedure will use the values 4.000 to 20.000 in the instructions if you are using a milliamp meter. If you are using a voltmeter across a resistor, select change and provide the values that you will be using at the current end points. The user must press ENTER when ready.



The HART Communicator now instructs the user to connect the reference meter that is to be used for the current calibration. The user must press OK when ready.



The Current Output calibration is now complete. The HART Communicator will now return the current output of the transmitter to normal operation.



The HART Communicator will now command the transmitter to set the current output to 4.000mA. The user must press OK when ready to have the current output set to 4.000mA.



The user is then notified that the loop may now be returned to automatic control. After the user presses OK the HART Communicator returns to the Calibration screen.



When the device has set the current output to 4.000mA, the user is to enter the reference meter reading. For example, if the meter actually reads 4.234mA, that value is input with the keypad. The user must press ENTER when the current value has been entered.

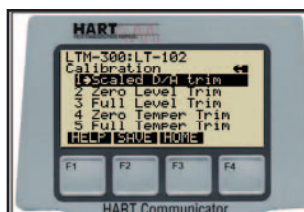

The HART Communicator is now at the starting screen for the Scaled D/A trim.

Zero Level Trim



Starting at the Calibration screen, select the Zero Level Trim procedure. This procedure trims the Level digital value measurement at the position that the user desires to be the zero reference position.



If the user selects Zero Level Trim from the Calibration screen, this screen will appear reminding the user that the loop should be removed from automatic control before proceeding. When this has been done, the user must press OK to continue.



This screen warns the user that proceeding will affect the sensor calibration. The user must press OK when ready to proceed.



The HART Communicator now requests that the level float be set to the desired zero level trim point. When the float is at this position, the transmitter will always report 0 in the user chosen units. The user must press OK when the float is at that position.



The transmitter will take several seconds to insure that the level signal has stabilized. Once the measurement is stable, the procedure will continue without user intervention. The HART communicator will then send the command to the transmitter to calculate the new Level zero calibration constant.



When the transmitter has completed its calculation it will reply to the HART Communicator. Then the HART Communicator will inform the user that the zero level point has been trimmed.



The user is then notified that the loop may now be returned to automatic control. After the user presses OK the HART Communicator returns to the Calibration screen.



The HART Communicator is now at the starting screen for the Zero Level Trim.

Full Level Trim



Starting at the Calibration screen, select the Full Level Trim procedure. This procedure trims the Level digital value measurement at two points. The first point is the position that the user desires to be the zero reference position. The second point is a Level position near the end of the sensor.



If the user selects Full Level Trim from the Calibration screen, this screen will appear reminding the user that the loop should be removed from automatic control before proceeding. When this has been done, the user must press OK to continue.

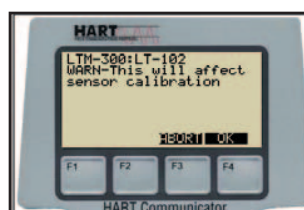

This screen warns the user that proceeding will affect the sensor calibration. The user must press OK when ready to proceed.



The HART Communicator now requests that the level float be set to the desired zero level trim point. When the float is at this position, the transmitter will always report 0 in the user chosen units. The user must press OK when the float is at that position.



The transmitter will take several seconds to insure that the level signal has stabilized. Once the measurement is stable, the procedure will continue without user intervention. The HART communicator will then send the command to the transmitter to calculate the new Level zero calibration constant.



When the transmitter has completed its calculation it will reply to the HART Communicator. Then the HART Communicator will inform the user that the zero level point has been trimmed.



The HART Communicator now requests that the level float be set to the desired level upper trim point. The second trim point can be any other level point but it is recommended that this point be as far away from the zero point as possible. When the float is at this position, the transmitter will always report the digital value entered in the user chosen units. The user must press OK when the float is at that position.



The transmitter will take several seconds to insure that the level signal has stabilized. Once the measurement is stable, the procedure will continue without user intervention. The HART Communicator will then send the command to the transmitter to calculate the new Level gain calibration constant.



The HART Communicator will now request the user to enter the value at the high trim point. The HART Communicator will display the last upper trim point, for example 60 in, and the user will enter the new upper trim point, for example 59.0 in. The HART Communicator will now send this value to the transmitter.



When the transmitter has completed its calculation of the new Level gain calibration constant, it will reply to the HART Communicator. Then the HART Communicator will inform the user that the level upper trim point has been trimmed. Then the HART Communicator will inform the user that the upper level trim point has been trimmed.

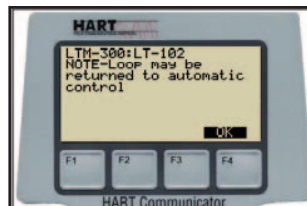

The user is then notified that the loop may now be returned to automatic control. After the user presses OK the HART Communicator returns to the Calibration screen.



The HART Communicator is now at the starting screen for the Full Level Trim.

Zero Temperature Trim



Starting at the Calibration screen, select the Zero Temper Trim procedure. This procedure trims the Temperature digital value measurement at the reference value of the RTD (1000 ohms).



If the user selects Zero Temper Trim from the Calibration screen, this screen will appear reminding the user that the loop should be removed from automatic control before proceeding. When this has been done, the user must press OK to continue.



This screen warns the user that proceeding will affect the sensor calibration. The user must press OK when ready to proceed.

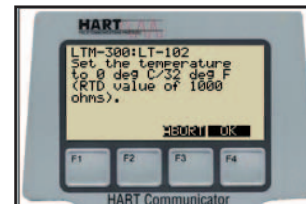

The HART Communicator now requests that the temperature be set to the desired 0 deg C temperature point. If using a temperature simulator, adjust the simulator temperature to 0 deg C or if using a resistance box, adjust the resistance value to 1000 ohms. The user must press OK when the RTD or simulator is at the required value.



The transmitter will take about fifteen seconds to insure that the temperature signal has stabilized. Once the measurement is stable, the procedure will continue without user intervention. The HART Communicator will then send the command to the transmitter to calculate the new Temperature zero calibration constant.



When the transmitter has completed its calculation it will reply to the HART Communicator. Then the HART Communicator will inform the user that the zero level point has been trimmed.



The user is then notified that the loop may now be returned to automatic control. After the user presses OK the HART Communicator returns to the Calibration screen.



The HART Communicator is now at the starting screen for the Zero Temper Trim.



The transmitter will take about fifteen seconds to insure that the temperature signal has stabilized. Once the measurement is stable, the procedure will continue without user intervention. The HART communicator will then send the command to the transmitter to calculate the new Temperature zero calibration constant.



When the transmitter has completed its calculation it will reply to the HART Communicator. Then the HART Communicator will inform the user that the zero level point has been trimmed.

Full Temperature Trim



Starting at the Calibration screen, select the Full Level Trim procedure. This procedure trims the Temperature digital value measurement at two points. The first point trims the Temperature digital value measurement at the reference value of the RTD (1000 ohms). The second point is a Temperature value near the upper end of the desired Temperature range.



The HART Communicator now requests that the temperature be set to the desired temperature upper trim point. If using a temperature simulator, adjust the simulator temperature to the desired temperature or if using a resistance box, adjust it to the corresponding resistance value for this temperature. The user must press OK when the RTD or simulator is at the required value.

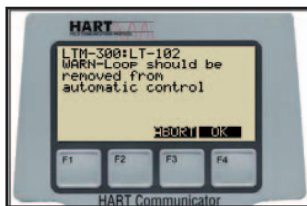

If the user selects Full Temper Trim from the Calibration screen, this screen will appear reminding the user that the loop should be removed from automatic control before proceeding. When this has been done, the user must press OK to continue.



The transmitter will take about fifteen seconds to insure that the temperature signal has stabilized. Once the measurement is stable, the procedure will continue without user intervention.



This screen warns the user that proceeding will affect the sensor calibration. The user must press OK when ready to proceed.



The HART Communicator will now request the user to enter the value at the high trim point. The HART Communicator will display the last upper trim point, for example 100 deg C, and the user will enter the new upper trim point, for example 75 deg C. The HART Communicator will now send this value to the transmitter.

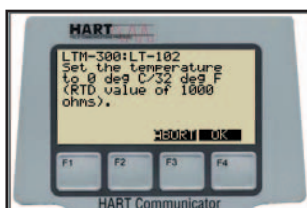

The HART Communicator now requests that the temperature be set to the desired 0 deg C temperature point. If using a temperature simulator, adjust the simulator temperature to 0 deg C or if using a resistance box, adjust the resistance value to 1000 ohms. The user must press OK when the RTD or simulator is at the required value.



The HART communicator will then send the command to the transmitter to calculate the new Temperature gain calibration constant. When the transmitter has completed its calculation it will reply to the HART Communicator. Then the HART Communicator will inform the user that the sensor upper temperature trim point has been trimmed.

Setting the Measurement Value for 4mA and 20mA by Keypad



The user is then notified that the loop may now be returned to automatic control. After the user presses OK the HART Communicator returns to the Calibration screen.



The HART Communicator is now at the starting screen for the Full Temper Trim.



If you desire to change the Level value at which the Current output is 4mA and 20mA when the Level is the selected Primary Variable, or change the Interface value at which the Current output is 4mA and 20mA when the Interface is the selected Primary Variable, the following procedure is used.



If the user selects Rerange from the Basic setup screen, a new menu screen will appear with the two choices Keypad rerange and Apply Values. The user will select Keypad rerange to change the 4mA and 20mA measurement values.



If the user selects Keypad rerange from the Rerange screen the user may change the LRV (4mA measurement value), the URV (20mA measurement value) or the Unit of measure. If Unit is selected by pressing the right arrow, a selection of units is available to the user.



This screen will show the user that in is the current user units and the user may select from ft, m, in or cm. When the user has selected the units that he desires by the up or down arrows, he must press ENTER to continue.

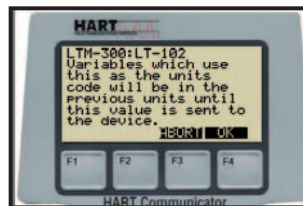

After the user has selected new units, he is warned that until he sends the new units code to the transmitter, all variables that use this units code will remain in the previous units code. The HART Communicator does not automatically send the new units code to the transmitter. The user must acknowledge this message by pressing OK to continue.



The user is returned to the Keypad rerange screen. Note that the label above F2 is now SEND. The user must press the SEND key for the HART Communicator to send the new units code to the transmitter.

Basic Setup Procedures



If a transmitter has been configured to measure both Level and Interface, the Basic setup screen will display the procedure Select PV on the second line. If a transmitter has not been configured to measure Interface, the second line will not appear.



If the user selects Select PV from the Basic setup screen, this screen will appear reminding the user that the loop should be removed from automatic control before proceeding. When this has been done, the user must press OK to continue.



The user must now select which variable, Level or Interface will be the Primary Variable. In other words, which variable will control the loop current output from the transmitter. In this example, the user selects Interf and must press ENTER when ready to proceed.



The HART Communicator sends the command selecting the variable to be the Primary variable, and the transmitter will respond when the change has been made. The user is then notified that the loop may now be returned to automatic control. After the user presses OK the HART Communicator returns to the Basic setup screen.



The HART Communicator will display this screen reminding the user that the loop should be removed from automatic control before proceeding. When this has been done, the user must press OK to continue.



On returning to the Keypad rerange screen, the values shown for LRV and URV are the changes that the user has made. The user should check the difference between the URV and LRV and compare this value with the Min span listed on the menu. If the difference is smaller than the minimum span, the transmitter will not accept the new range values. Note that the label above F2 is now SEND. The user must press the SEND key for the HART Communicator to send the new range values to the transmitter.



The user is then notified that the loop may now be returned to automatic control. After the user presses OK the HART Communicator returns to the Keypad rerange screen.



The HART Communicator will display this screen reminding the user that the loop should be removed from automatic control before proceeding. When this has been done, the user must press OK to continue.



If the user has changed the unit code, he may then modify the range values. He selects the variable that he desires to change by using the left arrow on the highlighted line.



The user is then notified that the loop may now be returned to automatic control. After the user presses OK the HART Communicator returns to the Keypad rerange screen.



If the user selects LRV from the Keypad rerange screen, the present LRV is displayed above the edit box, 0.00 in as shown to the left. In this example, the user desires to change the LRV to 10.0 in and must press ENTER after changing the edit box to continue with the reranging of the transmitter.



The keypad rerange screen now shows the new LRV, URV and Unit selected by the user.



The Keypad rerange screen now shows the new value selected by the user, but the HART Communicator has not sent the command to the transmitter. Note the SEND label above F2 that indicates the need to send the value to the transmitter.

Reranging the Transmitter Setting the Measurement Value for 4mA and 20mA by Apply Values



If the user selects URV from the Keypad rerange screen, the present URV is displayed above the edit box, 60.00 in as shown to the left. In this example, the user desires to change the URV to 55.0 in and must press ENTER after changing the edit box to continue with the reranging of the transmitter.



If the user desires to set the 4mA and 20mA measurement points by setting the Level (or Interface) value in the vessel, he must select Apply values from the Rerange screen.

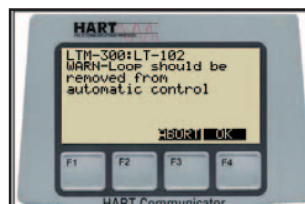

If the user selects Apply values from the Rerange screen, this screen will appear reminding the user that the loop should be removed from automatic control before proceeding. When this has been done, the user must press OK to continue.



The next screen gives the user a choice to set the 4mA or 20mA values or to Exit the procedure. Here the user will select the 4mA menu position.



If the user accepts the measurement value as the 20mA loop current point, the HART Communicator issues the command changing the URV and when the transmitter replies, returns to the Set screen



The HART Communicator requests the user to set the Level (or Interface) to the position that is to provide the 4mA loop current output. When that has been done, the user must press OK to continue with the procedure.



When the user desires to leave the Apply values procedure, he must select the Exit menu entry.



The HART Communicator then requests a measurement reading from the transmitter indicating the digital value at this range position. The user then has the option of setting this value as the lower range value, getting an update of the digital reading from the transmitter or leaving the 4mA range point as it was.



The user is then notified that the loop may now be returned to automatic control. After the user presses OK the HART Communicator returns to the Rerange screen.

Detailed Setup Selections



If the user accepts the measurement value as the 4mA loop current point, the HART Communicator issues the command changing the LRV and when the transmitter replies, returns to the Set screen.



In the Overview section, it was shown that if the user selects the Detailed setup menu from the Device setup screen, the following screen presents the following selection of menus to the user.



If the user desires to change the 20mA measurement value, he selects the 20mA menu option and must press ENTER to continue the procedure.



If the user selects Sensors from the Detailed setup screen, he may edit the Unit code for Level/Interface or edit the units code for Temperature. The third option is a menu Sensor Trim that gives the user additional selections.



The HART Communicator requests the user to set the Level (or Interface) to the position that is to provide the 20mA loop current output. When that has been done, the user must press OK to continue with the procedure.



If the user selects Sensor Trim from the Sensors menu, calibration procedure options are presented. If the transmitter is not configured for Temperature, the Zero Temper Trim and Full Temper Trim options will not be presented. The description of these procedures is given in the previous section on Calibration.

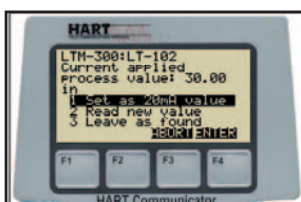

The HART Communicator then requests a measurement reading from the transmitter indicating the digital value at this range position. The user then has the option of setting this value as the upper range value, getting an update of the digital reading from the transmitter or leaving the 20mA range point as it was.

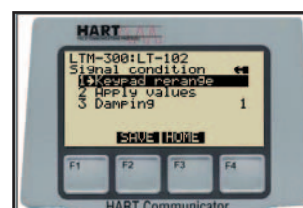

If the user selects Signal Condition from the Detailed setup screen, he is presented with three additional selections. The Keypad rerange and Apply values procedures are presented in the Rerange section. The third option allows the user to modify the Level/Interface damping factor.



If the user selects Output condition from the Detailed setup screen, he is presented with two menu selections, Analog output and HART output.



If the user selects Analog output from the Output condition screen, the Alarm type is displayed and two options for procedures, Loop Test and Scaled D/A trim. The Loop Test procedure is presented in the Diagnostics section and Scaled D/A trim is presented in the Calibration section.



If the user selects HART output from the Output condition screen, he may change the polling address of the transmitter and is given the number of request preambles required by the transmitter.



If the user selects Device information from the Detailed setup screen, nine items are displayed and one additional menu option is displayed. This portion of the list displays the items to the left.



The bottom half of the list of Device information items is shown to the left. The menu entry Revision #s will display the various revisions of the transmitter.



If the user selects Revision #s from the Device information screen, the screen to the left will display the revisions of the transmitter.



The user must press F3 to send the Level Offset to the LTM300.

Probe Length

The Probe Length is set in the factory when the unit is prepared for shipment. The probe length is used as a reference for a number of diagnostics functions as well as setting the URL and LRL shown on the Keypad rerange screens. If an amplifier is changed, it is important that this parameter be set to the proper value for the probe used.



The Probe Length parameter may be found by entering the Detailed setup menu and selecting Sensors.



Select Probe Length to view or edit



If the probe length is incorrect, provide the correct length and press ENTER.

Level Offset



Starting at the Sensors Screen, select Zero Offset and press ENTER. This procedure sets a 4mA point anywhere on the probe in reference to the end of the probe.



Enter the desired value of the offset from the bottom of the probe and press ENTER. This will show a level offset @ 4mA. i.e. 4mA will be reported @ 5.0" if 5.0" is selected.



When the communicator returns to the Sensors screen, the SEND button is highlighted. Press SEND to write the correct probe length to the amplifier.

The LTM-300 complies with the following standards:
IEC 60079-0, IEC60079-1
EN 50014, EN 50018



3902 Magnolia Road, Pearland. Texas. 77584

PH: 281/488-0788 FAX: 281/488-7080

EMAIL: magtech@isemagtech.com www.isemagtech.com